

UPA-II



Automatic Print/Apply Labeling System

FEATURES

- Prints labels on demand and applies them when signaled by its photoelectric product sensor
- Allows users to design labels with barcodes, pricing & sizing, product branding, and a wide variety of text and graphics
- Choice of print engines from leading manufacturers

The stand-mounted UPA-II System prints labels on demand and applies them to a wide variety of products. UPA-II is fully automatic, and it's the perfect companion for Amscomatic's automatic bagger/sealer. The system combines a UPA-II label applicator with a choice of print engines from leading manufacturers. Optional labeling software allows users to design labels with barcodes, pricing & sizing information, product branding, and a wide variety of text and graphics. Those designs are then downloaded from the computer to the printer, which then prints the completed label and positions it for application by the UPA-II. The labels are then affixed to products passing by when signaled by the machine's polarized photoelectric product sensor.

Standard printer resolution is 80 dots/cm (200 dpi); 120 dots/cm (300 dpi) resolution is optionally available. Excluding a computer, the system includes all hardware necessary to print & apply labels (optional labeling software is sold separately). Other options include a Label Low/Out Detector & Light Tree and Amscomatic's IC-110 horizontal transport conveyor.

Compared to manual labeling operations, the integrated UPA-II Print/Apply System provides dramatic improvements in quality,



Shown with optional horizontal conveyor

consistency and productivity. It's backed by a one-year limited warranty and M&R's unparalleled 24-hour access to service, support, and premium parts. The UPA-II is engineered for dependable performance and low maintenance in demanding, high-production environments, and can be easily integrated with other Amscomatic equipment into automatic folding/bagging/sealing systems.

SPECIFICATIONS

	UPA-II
Air @ 5,5 bar (80 psi)	142 l/min (5 cfm)
Electrical Requirements ¹	110 V, 1 ph, 5 A, 50/60 Hz, .06 kW
Overall Size (L x W x H)	116 x 95 x 171 cm (45.5" x 37.5" x 67.25")
Shipping Weight	113 kg (250 lb)

¹ If incoming voltage differs from the voltage(s) listed in this brochure, calculate amperage accordingly. Other electrical configurations are available. Contact The M&R Companies for details.



L-15H™



Automatic Label Applicator

FEATURES

- Applies labels automatically during the folding process to increase efficiency
- Product sensor ensures accurate label placement
- Allows label placement anywhere on the front of the garment

Amscomatic's high-speed label applicator is designed to automatically apply labels to garments as they pass through an automatic folding machine. Positioned on the folder, the L-15H simplifies setup, label loading, and label positioning. With a folder-activated product sensor, variable timer, and adjustable mount, the L-15H allows label placement virtually anywhere on the front of the folded garment. The L-15H can be easily integrated with new and older Amscomatic automatic folders, as well as with some other brands of folding machines.

The L-15H has a 7.62 cm (3") label core capacity, and is designed to speed label loading and changeover. It mounts directly to the folder, and features variable side-to-side label location. An optional floor stand adds flexibility by allowing the L-15H to be positioned over a conveyor. Amscomatic also supplies printers for printing labels prior to application. The L-15H is built to specifications established by the European Committee for Standardization® (CE) and Underwriters Laboratories® (UL) and it's backed by a one-year limited warranty. The L-15H is engineered for dependable performance and low maintenance in demanding, high-production environments, and

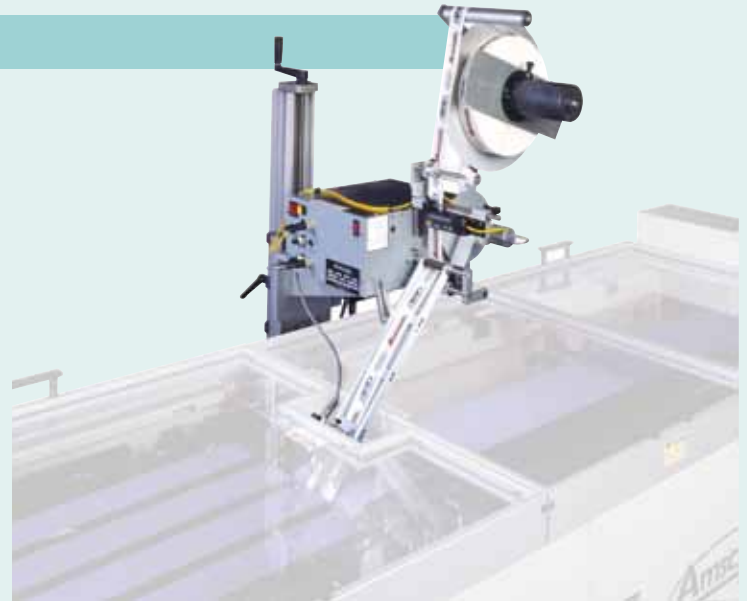

can be easily integrated with other Amscomatic equipment into automatic folding/bagging/sealing systems.

All equipment from The M&R Companies is built with M&R's unsurpassed attention to detail and commitment to quality, durability, innovation, and design excellence, and is backed by M&R's unparalleled 24-hour access to service, support, and premium parts. It's no wonder M&R is the first name in screen printing equipment.

SPECIFICATIONS

	L-15H
Electrical Requirements ¹	110 V, 1 ph, 7 A, 50/60 Hz, 0.77 kW
Overall Size (H x W x D)	49.5 x 58.4 x 62.9 cm (19.5" x 23" x 24.75")
Shipping Weight	91 kg (200 lb)

¹ If incoming voltage differs from the voltage(s) listed in this brochure, calculate amperage accordingly. Other electrical configurations are available. Contact The M&R Companies for details.



The M&R Companies
M&R • NUARC • AMSCOMATIC

The M&R Companies 1N372 Main Street, Glen Ellyn, Illinois 60137-3576 USA

USA: 800-736-6431 / 630-858-6101 / Fax: 630-858-6134 • Outside USA: +1-847-967-4461 / Fax: +1-847-967-0417

M&R Printing Equipment, Inc. and its subsidiaries (hereinafter M&R), believe the information in this advertisement to be accurate at publication, though it does not purport to list all manufacturing and specification variations, nor does it assume liability resulting from incompleteness or inaccuracy. M&R reserves the right to change specifications without notice. M&R expressly disclaims any liability for damages, consequential or incidental, from purchase, installation, servicing, and/or use of any product/service based upon information herein. No warranties of merchantability or fitness for a particular purpose are made or are to be implied from the information herein. No information herein may be reproduced or used in any manner without the prior, express written consent of M&R in each case. Copyright 2011 M&R Printing Equipment, Inc. All rights reserved. 080211