

# PICTORA

HIGH SPEED DIGITAL BOARD REPRODUCTION



## SITE PREPARATION GUIDE

The information contained herein is subject to change without notice. The only warranties for Novus Imaging products and services are set forth in the Sales Agreement to accompany such products and services. Nothing herein should be construed as constituting an additional warranty. Novus Imaging shall not be liable for technical or editorial errors or omissions contained herein.



**Table of Contents**

Site Preparation Guide .....	1
Table of Contents .....	3
Shipping and Delivery Specifications .....	5
Printer Specifications .....	5
Printer on Pallet .....	5
Printer Removed from Pallet .....	5
Sheet Media Input/Output Tables .....	5
Electrical Requirements .....	5
Compressed Air .....	5
Environmental .....	5
Printer Shipping and Delivery .....	6
Receiving the Equipment .....	6
Delivery Logistics .....	6
Detailed Printer Delivery Information .....	6
Accepting Delivery .....	6
Necessary Equipment at Receiving Destination .....	7
Flooring .....	7
Ink and Substrate .....	7
Unloading and Positioning .....	8
Lifting .....	8
Lifting and Moving by Crane .....	8
Removing Printer from Pallet .....	9
Site Preparations .....	11
Safety .....	11
Network .....	12
Electrical Power .....	13
Compressed Air Information .....	14
Air Quality .....	14
Maintaining Air Quality .....	14
Air Quality Specifications .....	14
Location of Air Connector and AC Cable .....	15
Recommended Air Filtration System .....	16
Technical Specifications .....	16
RIP Environment .....	17
Apple Macintosh Computer System .....	17
Linux Minimum Recommended Hardware Requirements: .....	17
Environmental .....	18
Floor Space .....	18
Customer Site Preparation Checklist .....	19
Delivery, Unpacking and Install Preparation .....	19
Compressed Air .....	20
Network .....	20

## Table of Contents

Supplies and Training .....	20
Signature and Agreement .....	20
Customer Acceptance Agreement .....	21
Signature and Agreement .....	21

# Shipping and Delivery Specifications

## Printer Specifications

- Maximum Media Size: 30" x 36"
- Media: Sheet
- RIP: Caldera Grand RIP+
- Print Head Tech: Variable Drop Piezo Inkjet, 8 Print heads per color
- Ink Type: Novus UV27
- Colors: CMYK Orange and Gray, Optional UV Reactive Ink
- Optional Loader and Unloader
- Addressable Resolution: Full Grey Scale, Apparent Resolution 2400 dpi

## Printer on Pallet

- Weight: 4000 lbs and 1500 lbs, Machine ships on 2 pallets

## Printer Removed from Pallet

- Height: 84.0 inches (213.4 cm)
- Width: 132.0 inches (335.28 cm)
- Length: 156.0 inches (396.24 cm)
- Weight: 3500 lbs.

## Sheet Media Loader / Unloader

- Stack Height: Up to 24.0 inches (53.3 cm)
- Stack Weight: Up to 150 lbs (68 kg)

## Electrical Requirements

- Three phase 400V - 208V switchable, 40 amps, 50/60 Hz

## Compressed Air

- 110 psi 7.7 kgf/cm<sup>2</sup> at 9 CFM and a maximum 145 psi 10.2 kgf/cm<sup>2</sup>
- 1/4" NPTF Male fitting on printer

**Note:** Customer supplied Female Air fitting, [Figure 1-6](#).

## Environmental

- Temperature 55<sup>0</sup>f to 85<sup>0</sup> f (13<sup>0</sup>c to 29<sup>0</sup> c)
  - Humidity: Greater than 55% non condensing
-

# Printer Shipping and Delivery

Novus Imaging is responsible for delivering each printer to its designated site. Each printer is delivered in an enclosed, Air-Ride equipped trailer. Therefore, the printer pallet or crate is not accessible from either side, only the ends. You are responsible for choosing and hiring a rigger to unload your printer once it arrives at your facility. Provide your rigging company with the Printer Specifications for proper fork lift truck sizing.

## Receiving the Equipment

It is your responsibility to pay for all freight and moving expenses and for ensuring proper receipt of the printer. Any damage incurred while the printer is being unloaded, moved or placed into position is not the responsibility of Novus Imaging. The shipper is responsible for delivering the printer to your site without damage.

## Delivery Logistics

Where possible, every printer sold in the continental United States is delivered via air ride truck. In the event of an ocean freight delivery, the printer is crated and vapor sealed.

Before the printer arrives, perform the following tasks:

- Determine whether you will require a permit for street or building access or moving the printer into your building.
- Hire a professional, bonded, insured rigging company to move the printer from the truck to the installation site. If you need assistance, your Novus Imaging sales representative will assist you.
- Ensure that all doors and hallways between the loading dock and the final installation site exceed the measurements for crated or palletized printer.
- Ensure that the flooring along the path between the loading dock and the final installation site is level and able to support the weight of both the printer, packaging materials, and fork lift truck.

The crated or palletized printer should be moved or positioned by competent, bonded, insured riggers. Any damage occurring as a result of moving or positioning the printer is the customer's responsibility.

## Detailed Printer Delivery Information

When hiring a moving company or a rigger be sure to obtain copies of all relevant insurance and bond policies prior to scheduling delivery. As the customer, you are responsible for insurance and bond verification of the total value of the printer and any accessories prior to scheduling delivery.

## Accepting Delivery

When the printer arrives at your facility, carefully inspect the crate and packaging prior to unloading from the truck. Carefully inspect and look for signs of damage that may have occurred during shipping. Verify the package count against the packing slip.

Prior to unloading the printer from the truck, ask the shipper the following questions

- Were there any issues with the transport and delivery of the printer?
- Is there any visible damage to the printer packaging or crating?
- Does the package count differ from the packing slip?

If the answer to any of the questions is Yes, contact Novus Imaging (603-513-0345) immediately and note the information on the packing slip. Take pictures of any damage identified prior to unloading and after unloading.

Any damage or missing items must be reported immediately to the shipping company listed on the delivery slip, as well as Novus Imaging. If items are missing, mark the packing slip accordingly.

## Necessary Equipment at Receiving Destination

There are two possible options for delivery:

- A Loading Dock is the most desirable option. Ideally a loading dock equal in height to the delivery truck. In this fashion, the rigging company can easily drag the printer off the truck.
- No Loading Dock will require a second fork lift truck to unload the printer from the trailer.

## Flooring

Ensure that the flooring along the path between the loading dock and the final installation site is level and able to support the weight of both the printer, packaging materials, and fork truck

Novus Imaging printers are aligned at the factory to very tight tolerances. In order to maintain printer alignment, the printer must be installed on a solid, smooth, unmarred and stable concrete floor. If you find any defects in the flooring, it must be corrected with plates to perfectly level the surface. Floor surfaces that flex or transfer vibrations, such as wood, or steel, are not acceptable.

If the printer is installed on a floor that cannot adequately support its weight, the printer can move or twist. This movement results in damage, leading to significant misalignment and other potential problems.

Novus Imaging is not responsible for print quality issues or damage to the printer resulting from an unstable floor. The flooring beneath the printer must be:

- A solid concrete base capable of supporting the printer's weight.
- A level surface, free of any vibration.
- Easily cleaned (free of dust and static electricity).

**Warning:** Never lift the printer from either end if the crate, pallet and/or shipping brackets have been removed. This will cause irreversible damage to the printer.

## Ink and Substrate

Initial ink and consumables orders need to be completed while you are preparing your site, and before the printer arrives. **THESE ITEMS MUST BE AT YOUR LOCATION BEFORE THE PRINTER SETUP BEGINS.** You may purchase substrates from Novus Imaging or from another vendor. A Novus Imaging printer comes with a starter kit containing enough ink and consumables for setup and testing. You should order additional ink and consumables for production. Novus Imaging recommends ordering at least one case of each ink color. Depending on production needs, increase these quantities in order to avoid downtime due to lack of supplies.

## Unloading and Positioning

The crated or palletized printer may be dragged from either end. This is useful when removing the printer from the truck in which it was shipped.

**Warning:** Never lift the printer from either end if the printer was removed from the pallet. This will cause irreversible damage to the printer.

Lift the end of the crated or palletized printer about 12 inches (30 cm) off the trailer to slide the printer off the truck.

The end pallet slots are designed to allow lifting forks to slide only 60 inches (152 cm) under them — thus preventing any attempt to completely lift the full weight of the pallet from either end.

**Caution!** Do not attempt to slide the crated printer over uneven or sloped surfaces; or surfaces that may be damaged by the weight of the printer (such as wood, vinyl, or carpet).

Other than removing the printer from the shipping truck, we do not recommend sliding the printer more than 10 feet (3 meters). Lifting is recommended for longer distances.

### Lifting

Lift the entire weight of the printer from either the front or the rear. Do not lift the printer from either end.

Because the printer pallet has extended width, and the weight of the printer is unevenly distributed, a fork lift truck with a minimum of 60" (153 cm) forks must be used.

**Note:** Save the shipping brackets and bolts in case the print is relocated in the future.

### Lifting and Moving by Crane

If moving the printer using a crane or other lifting equipment (i.e., hoist/chain fall), take special precautions to prevent damage to the printer. Verify that the crane/lift can adequately support the total of the following:

- The weight of the printer - See the Printer Specifications for the total weight of the printer.
- The weight of the crate and packaging materials. Verify that the slings used to lift the printer are placed according to the markings on the crate or packaging, depending on the shipping method.

**Warning:** Once the printer is removed from the shipping crate/pallet, the printer leveling feet must be installed. The entire printer must be off the floor to install the leveling feet.



## Removing Printer from Pallet

**Caution!** You will need a Fork Lift Truck capable of lifting 10,000 pounds to remove the printer from the Pallet. The forks of the Fork Lift must be 66" (168 cm) or longer.

1. Leave the Angle Brackets attached to the Pallet.
2. Remove the bolts that attach the Angle Brackets to the printer frame.
3. Place the forks of the fork lift truck into the lift slots at the bottom of the printer. The lift slots are 66" long (168 cm).

**Warning:** Ensure the forks extend beyond the opposite end of the lift slots. The preference is to lift the printer from the front.

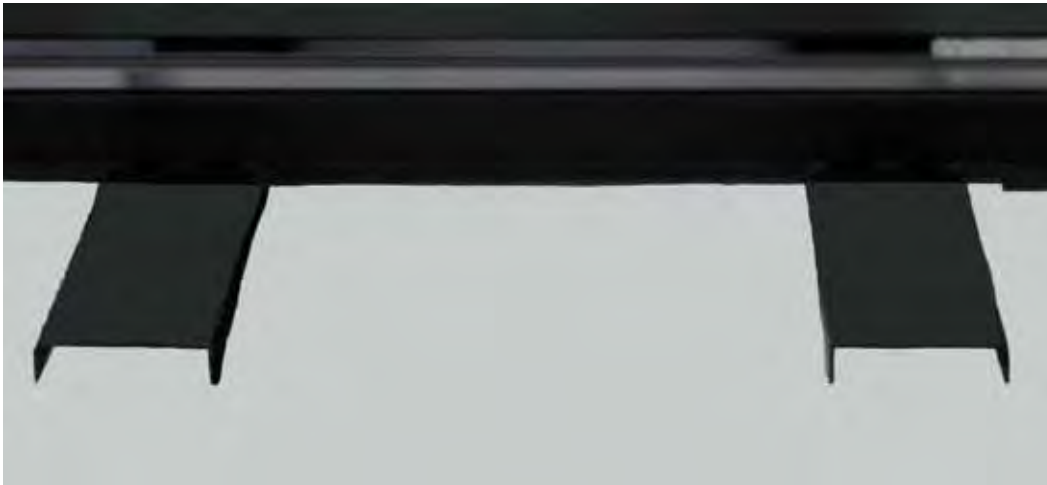

**Figure 1-1: Lift slots at bottom front and rear of printer**

4. Before setting the printer in its final position, rotate the wheel and leveling foot so the adjustment nut is easily accessible, [Figure 1-2](#). There is a leveling foot at each corner of the printer.

**Note:** Once the printer is sitting on the wheels, the wheels cannot be turned to access the adjustment nut.



**Figure 1-2: Leveling foot and adjustment nut**

## Site Preparations

Preparing the site is the most important element to building a foundation for future printing success. You are responsible for contracting with local resources not affiliated with Novus Imaging. These resources may include:

- Local safety code specialists
- Heating, ventilation, and air conditioning (HVAC) professionals
- Licensed electricians
- Pneumatic (compressed air) systems professionals
- Network professionals
- RIP Work Station procurement and setup

## Safety

Check with your local Occupational Health and Safety Agency (OSHA), and the fire department for codes governing safety in the workplace.

- Teach basic safety principles to all users and operators.
- Post safety signs in key areas to alert personnel of potential dangers.
- Install eyewash stations in easily accessible locations near the printer.
- Store flammable materials (such as solvents) in specially designed and clearly labeled Storage cabinets.
- Install fire extinguishers containing CO<sub>2</sub> in a clearly visible spot within 25 feet (7.6m) of the printer.

**Note:** For additional safety information, please read the Synergia H/UV Safety Guide.

## Hazardous Waste

Because your printer consumes ink a certain amount of hazardous waste will be generated. It is important to understand and comply with all local regulations governing the handling and disposal of these wastes.

## Network

Before the printer is installed, the Pre-Press computer and Network need to be in place and configured for connection to your Novus Imaging printer. Hiring a network professional, or having one on staff, helps ensure that your facility and network are configured properly.



**Figure 1-3: Facility Ethernet connector left rear**

**Warning:** Do not connect the Facility Ethernet cable to the **internal** Ethernet Hub. Connect the Facility Ethernet cable to the Ethernet connector shown in the above picture.

# Electrical Power

You are responsible for providing the electrical power for your Novus Imaging printer. All required power connections and cables must be in place before the Service Engineer arrives. Customers must supply power feeds and returns. Because of variances in local codes, power cables are not included with the printer and must be supplied by the customer. Size shall be determined by local electrical code requirements.

Facing the printer, the customer supplied AC Power is installed on the top left side of the printer, [Figure 1-5](#). From the outside of the printer to the internal AC connector block the length of the cable is approximately six feet.

A licensed electrician should ensure that the printer's dedicated power source meets your printer's requirements.

- 400 - 208 VAC  $\pm 10\%$ , 50A, 60 Hz, three-phase, [Figure 1-4](#)
- Peak rated current 40 Amps
- Peak power consumption 20 kVA/kW
- Continuous power consumption 17 kW
- Three-Phase Electrical Configuration

You will need to contract with a locally licensed and certified electrician to ensure that your printer's wiring and electrical connections comply with your printer's specifications, and are in accordance with all local code requirements.

There are two required visits: the first to install the electrical line, and the second to complete the connection to the printer.

**Note:** All wires on the main power line must have a ferrule to assure a solid connection.

The main power cable's protective earth ground wire must contain a service loop housed inside the printer. This ensures ground is the last connection broken in the event the cable is forcibly pulled out of the printer. All required power connections and cables must be in place before the Novus Imaging Service Engineer arrives at your facility.

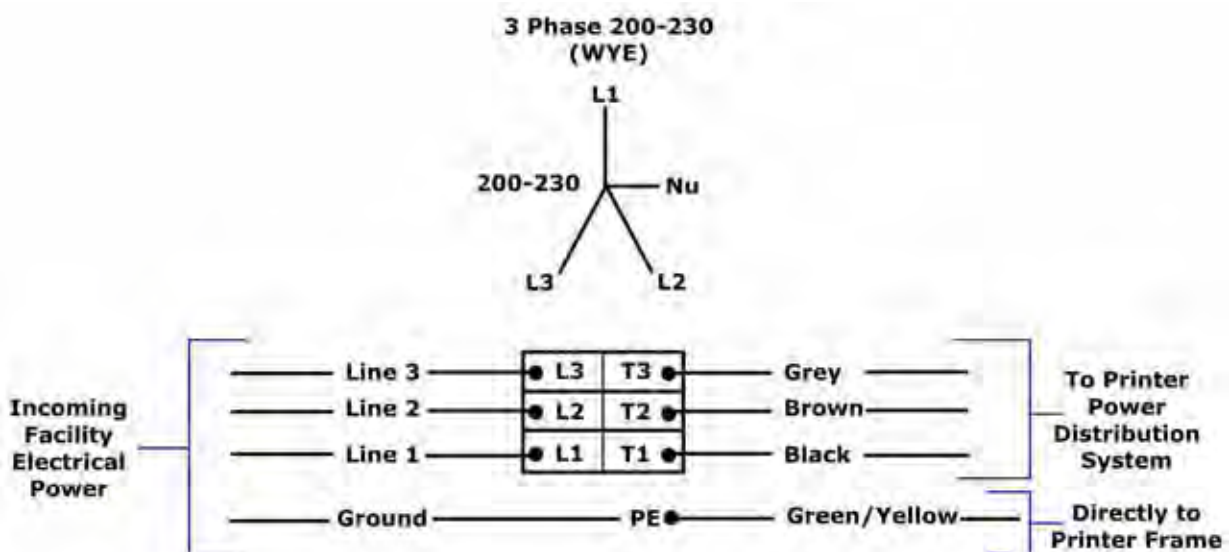

**Figure 1-4: AC input diagram**

## Compressed Air Information

A compressor and air system that supplies clean dry air at a minimum of 110 psi 7.7 kgf/cm<sup>2</sup> at 9 CFM and a maximum 145 psi 10.2 kgf/cm<sup>2</sup> is a typical requirement. However, at 9 CFM (255 liters/minute) the compressor may need to run 100% of the time, therefore a more economical compressor system would provide 15 CFM (425 liters/minute) at 110 PSI.

Systems that are designed to supply greater volumes of air have the advantage of longer life for the associated components and require less maintenance to keep the system functioning within the stated air quality specifications.

**Note:** As a guide, air quality for your printer should meet or exceed the requirements for automotive paint spraying applications.

You are responsible for providing the compressed air required to operate your Novus Imaging printer. Novus Imaging does not supply air compressors or compressed air filtration systems with its printers. Novus Imaging recommends consulting a pneumatic systems professional to design and install your system.

### Air Quality

Since compressed air contains oil and dirt particles that damages regulators, solenoids, and Print Heads, each printer requires a filtration system installed between the compressor and printer.

**Note:** Substances like oil, or silicone, should never be used in the system, as this reduces print quality.

Novus Imaging printer components, including Print Heads, that are damaged because of poor air quality are not covered under the warranty program.

### Maintaining Air Quality

One method of meeting compressed air specification requirements is to install a point-of use filtration system. A point-of-use system filters the air as close to the point of use as possible. Filtering the air closer to where it is used reduces contamination resulting from the delivery system, as well as the possibility of water vapor due to condensation.

#### Point of Use Filtration System

A point-of-use filtration system should consist of:

- Stage I: 5 micron general-purpose filter to remove oil, water droplets, and particulate matter.
- Stage II: 0.01 micron coalescing filter to remove oil and particulate matter.
- Stage III: Desiccant drier for ultra-dry air.

### Air Quality Specifications

Class 1: Oil and Particulate

Oil vapor (maximum): 0.01 mg/m<sup>3</sup>

Particulate size (maximum): 1 micron Class 2: Water Vapor

Water vapor (maximum): Standard pressure dew point -40° F (-40° C)

This specification covers particulate matter, oil, and water vapor and is the equivalent of International Organization for Standardization specification ISO 8573.1, International Standard for Compressed Air Quality

## Location of Air Connector and AC Cable



**Figure 1-5: Top left side of printer**

<b>Fitting Type</b>	
Male (On Printer)	1/4" (0.635 cm)
Female (Three Types)	1/4" (0.635 cm)



**Figure 1-6: Three types of connectors on female air fitting**

## Recommended Air Filtration System

The following suggested system is not a requirement, however, clean, dry air is required for your Novus Imaging printer.

DeVilbiss DAD-500 Three-Stage Desiccant Unit Approximate Retail Cost: \$529.99 DAD-500 air-drying system includes three filtering units, as well as a wall mount bracket and desiccant filter change indicator. Centrifugal and coalescer units include automatic bowl drain (standard feature), so there is no need to manually drain the system. Desiccant filter includes sight glass indicator (changes color when desiccant needs replacement). Made in USA.



**Figure 1-7: Air Filtration suggested configuration**

The three-stage desiccant components provide clean, dry air.

- First stage centrifugal filter removes particulates to 5 microns
- Stage two coalescer filters down to 0.01 micron
- Third stage desiccant removes remaining water vapor to a dew point of -40°F
- Ideally suited for low to medium production

### Technical Specifications

- Centrifugal Filtering Capacity: 5 micron
- Coalescer Filtering Capacity: 0.01 micron
- Flow Rate: 25 cfm
- Regulated Press. Range: 0-125 psi
- Max. Air Inlet Press.: 150 psi
- Max. Operating Temp.: 150° F



- Bowl Capacity: 17 Ounce (503 cc)
- Main Air Inlet: 1/2" NPT (F)
- Regulated Outlets: (1) 1/4" NPS (M)
- Air Regulators Included: (1) HAR-507
- Air Gauges (0-160 psi)
- Replacement Filters: HAF-6, HAF-28, DAD-1

## RIP Environment

In order to prepare images for printing, images are pre-processed, or Ripped. Caldera is the only supported RIP for Novus Imaging printers. Caldera runs on either an Apple OS X or Linux environment.

**Warning:** All Ripped files must reside on the Printer's Hard Drive. Do not print a Ripped file over the Network. The high data throughput requirements in printing an image exceeds the bandwidth of the Network.

### Apple Macintosh Computer System

A complete system matching the following hardware requirements must be dedicated to the Mac OS X v 10.4/10.5/10.6 operating system and the Caldera Software.

Apple Minimum Recommended Hardware Requirements:

- OS X v 10.4/10.5/10.6 Dual Core 2 Ghz
- 2 Gb RAM, 4 recommended
- 250 Gb Hard Drive
- DVD R/W Drive
- Monitor resolution 1280x1024

### Linux Minimum Recommended Hardware Requirements:

- Kubuntu 7.04/8.04 (Including Caldera Graphics delivery)
- A complete system matching the following hardware requirements must be dedicated to the Kubuntu 7.04 or 8.04 operating system and the Caldera software

#### Minimum Recommended Hardware Requirements:

- Dual Core 2 Ghz
- 2 GB RAM, 4 GM Recommended
- 250 GB Hard Disk, Minimum
- DVD R/W Drive
- Monitor Resolution 1280 x 1024
- Three Button USB Mouse

**Note:** The hard drive may be larger to store more files. NTL files can be very large and are generally not stored on a hard drive. If it is necessary to archive NTL files, it is recommended they be written to a DVD.

## Environmental

Novus Imaging does *not* supply a ventilation system for your printing system.

Customers must maintain the following environmental conditions for the printer and the area in which it is installed.

- Ambient room temperature 68° F - 85° F (20° C - 30° C)
- Relative humidity (non-condensing) 30% - 80%
- Volume 500 cf/m (14.2 m<sup>3</sup>/min)
- Inches of water 1.5 - 2.0 inches (38 - 55 mm)
- Exhaust collar diameter 10 inches (25.4 cm)
- Maximum under hood temperature 104° F (40° C)

## Floor Space

The NOVUS printer requires a minimum amount of floor space to allow for the operation, loading and unloading media, and maintenance procedures. The following shows the minimum floor space required, as well as the additional space for removing the printed images.

### Area

- Height: 84.0 inches (213.4 cm)
- Width: 132.0 inches (335.28 cm)
- Length: 156.0 inches (396.24 cm)

The printer should be installed to allow media to be loaded and unloaded while maintaining a minimum of 40" (101.6 cm) clearance around the printer and Loader / Unloader.

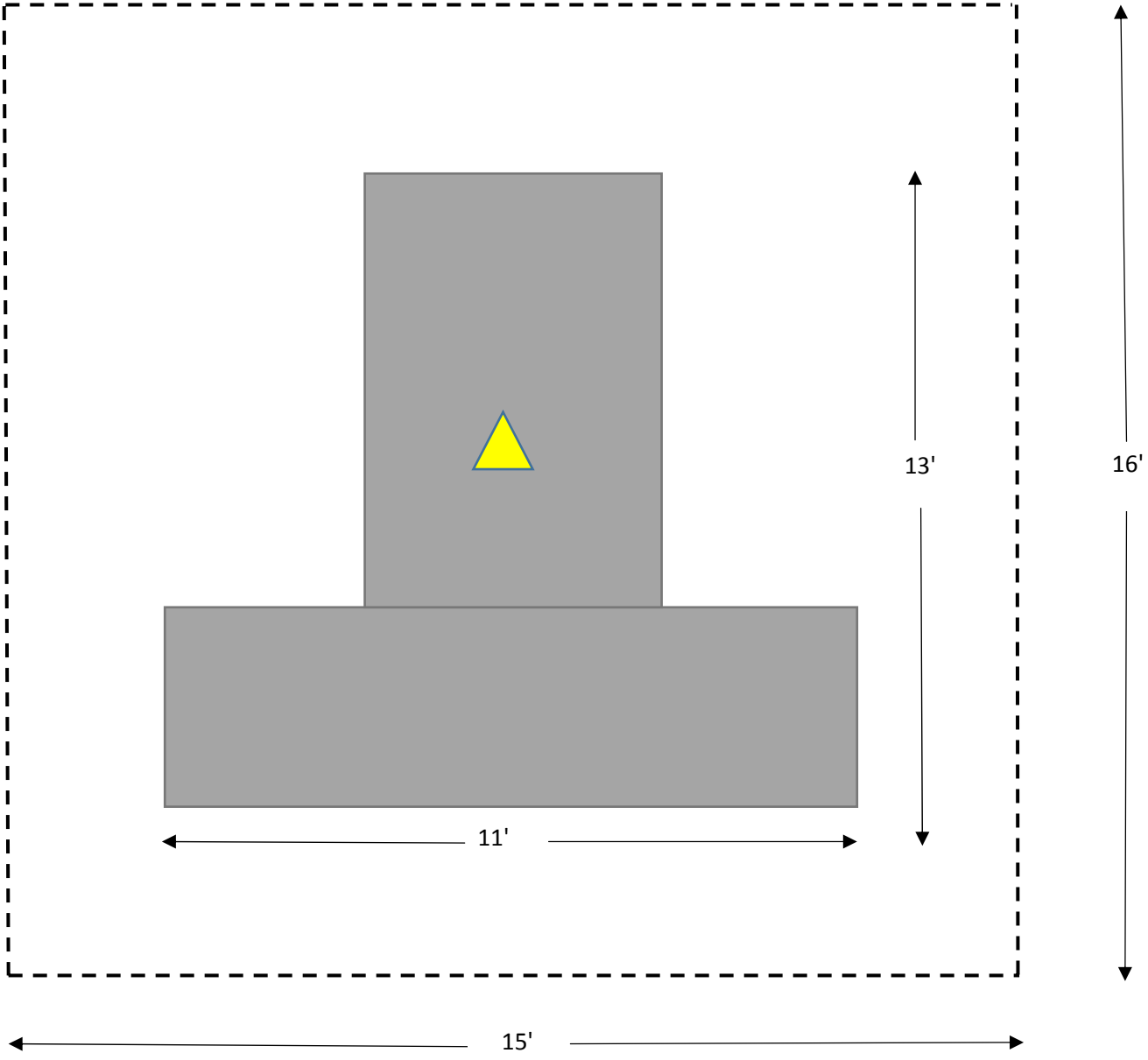

- - - - Working Area

 Approximate location for exhaust & air drops

# Customer Site Preparation Checklist

To be completed by purchaser of equipment at earliest possible date.

**Company Name:** \_\_\_\_\_

**Address:** \_\_\_\_\_

**City:** \_\_\_\_\_ **State:** \_\_\_\_\_

**Zip Code:** \_\_\_\_\_ **Country:** \_\_\_\_\_

Contact	Name	Phone	E-mail
Owner			
Main Printer Operator			
System Administrator			
Company Technician			
Main Operator trained on RIP, Printer Operator, and Maintenance			

## Delivery, Unpacking and Install Preparation

- Accessible loading dock location for receipt of printer
- Delivery schedule, use of freight elevators, hallways, doorways and access to receiving dock has been discussed and approved with building management
- Heights and widths of all hallways and doorways from loading dock to installation site exceed required measurements of palletized printer
- Final installation site floor is concrete and adequate to support weight of printer
- Installation site operating environment meets the temperature and relative humidity requirements
- Power feeds and returns are installed according to local and state code requirements

**Note:** Because of variances in local codes, the AC power cable is not included with the printer and must be supplied by the customer.

- Consistent AC power with UPS backup is in place for safe operating conditions
- Ground wire for single point ground to an isolated facility ground is installed. Size shall be determined by local code requirements

- Licensed electrician certifies printer's dedicated power source meets printer's power requirements

## **Compressed Air**

- Compressor/Air System in place to meet printer's filtered, clean dry compressed air requirements

## **Network**

- Network professional has installed networking interface and is available to support network equipment during installation

## **Supplies and Training**

- Ink is available at the site prior to arrival of a Novus Imaging technician.
- Novus Imaging approved media and substrate materials are available at site prior to arrival of a Novus Imaging technician
- Appropriate storage space is available for all ink, media, and substrate materials

## **Signature and Agreement**

**Printed Name:** \_\_\_\_\_

**Signature:** \_\_\_\_\_

**Title:** \_\_\_\_\_

**Date:** \_\_\_\_\_

By my signature above, I certify that I have read and understand the content of this document and have prepared my facility to the required specifications.

To be completed by purchaser of equipment at earliest possible date.

# Customer Acceptance Agreement

**Company Name:** \_\_\_\_\_

**Address:** \_\_\_\_\_

**City:** \_\_\_\_\_ **State:** \_\_\_\_\_

**Zip Code:** \_\_\_\_\_ **Country:** \_\_\_\_\_

**Company Representative:** \_\_\_\_\_

This Acceptance is based on the successful completion of the Novus Imaging installation.

By signing below, the undersigned hereby agrees to the acceptance of the NOVUS printer.

Serial Number \_\_\_\_\_ has been received in good condition and repair and that the product performance meets Novus Imaging specifications.

The undersigned hereby agrees to the start of the warranty period, and to pay the balance of the payment terms indicated in the Payment Terms section of the Novus Imaging Sales Agreement delivered by and between Novus Imaging, Inc. and that all contractual terms commence or remain in full affect.

## Signature and Agreement

### Customer Signature:

**Signature:** \_\_\_\_\_

**Printed Name:** \_\_\_\_\_ **Date:** \_\_\_\_\_

### Novus Imaging Representative Signature:

**Signature:** \_\_\_\_\_

**Printed Name:** \_\_\_\_\_ **Date:** \_\_\_\_\_

### Witness Signature:

**Signature:** \_\_\_\_\_

**Printed Name:** \_\_\_\_\_ **Date:** \_\_\_\_\_