

### YASKAWA J7 DRIVE

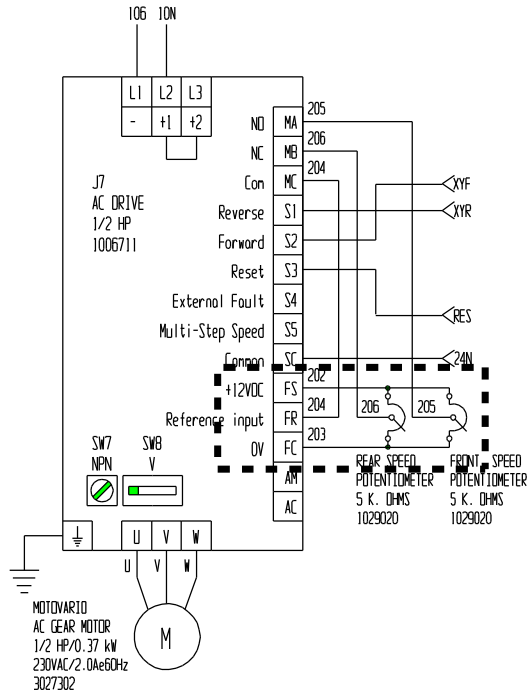

#### YASKAWA J7 PARM LIST:

N10 = 230	N41 = 88
N12 = 3.0	N42 = 9
N13 = 19	N43 = 0.0
N15 = 15	N52 = 0
N16 = 0.1	N54 = 0.1
N17 = 0.1	N54 = 4.3
N32 = 2	N72 = 2
N33 = 1	N75 = 1
N37 = 5	N77 = 1
N40 = 16	N79 = 20

NOTE FOR J7:  
V+ = FS  
A1 = FR  
AC = OV

### YASKAWA J1000 DRIVE

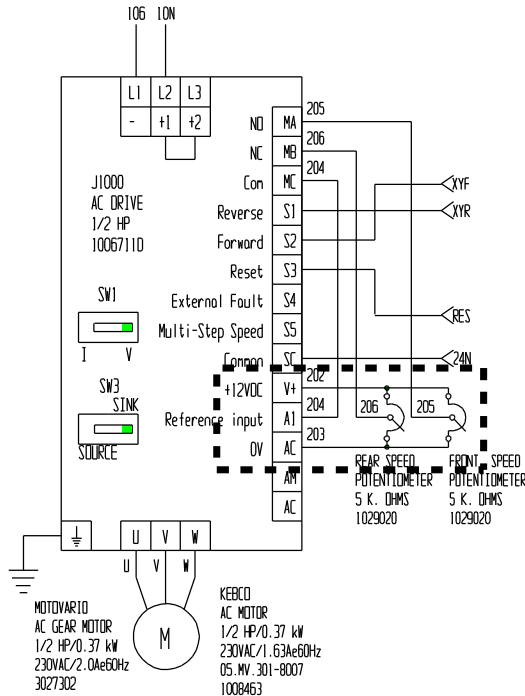

#### YASKAWA J1000 PARM LIST:

B2-02 = 0.0	DC BRAKING CURRENT
B2-03 = 0.1	DC BRAKING TIME
C1-01 = 0.1	ACCEL TIME
C1-02 = 0.1	DECEL TIME
C2-01 = 0.0	SCURVE
C2-02 = 0.0	SCURVE
C2-03 = 0.0	SCURVE
C2-04 = 0.0	SCURVE
C6-01 = 0	DUTY SELECT
C6-02 = 4	CARRIER FREQ
E1-05 = 230	MAX OUTPUT (V)
E1-07 = 3	MID OUTPUT FREQ
E1-08 = 19	MID OUTPUT FREQ (V)
E1-10 = 15	MIN OUTPUT FREQ (V)

MOTOVARIO MOTOR	E2-01 = 2.00	MOTOR RATED (A)
	E2-02 = 4.3	MOTOR RATED SLIP
	E2-03 = 1.65	MOTOR NO-LOAD (A)
	E2-05 = 15.656	MOTOR RESISTANCE
	H1-01 = 40	FORWARD
	H1-02 = 41	REVERSE
	H1-03 = 14	OUTPUT S3
	H1-04 = 0F	NOT USED
	H2-01 = 1A	MULTI-FUNC. OUTPUT
	H3-03 = 100	TERMINAL A1 GAIN
	H3-04 = 9	TERMINAL A1 BIAS
	H3-13 = 0	ANALOG IN FILTER TIME CONSTANT
	L1-01 = 2	OVERLOAD SELECTION
	L8-38 = 0	CARRIER FREQ REDUCTION

### CHANGING PARAMETERS SETTINGS OR VALUES

This example explains changing C6-02 (Carrier Freq) from 07 to 04

Step	DISPLAY
1. Turn on the power. The initial display appears.	F 0.00
2. Press the "UP" key until "Par" is displayed.	Par
3. Press the "ENTER" key to enter the parameter screen.	A1-01
4. Scroll through parameters by pressing "UP" key until the letter of parameter needed to be changed is displayed.	C1-01
5. Press ">/RESET" key until parameter number is selected indicated by the number flashing.	C1-01
6. Press arrow "UP" or "DOWN" key select the desired number.	C6-01
7. Press ">/RESET" key until parameter sub number is selected indicated by the number flashing.	C6-01
8. Press arrow "UP" or "DOWN" key select the desired number.	C6-02
9. Press the "ENTER" key to view the current parameter value.	07
10. Press ">/RESET" key until number is selected indicated by the number flashing.	07
11. Press arrow "UP" or "DOWN" key select the desired number.	04
12. Press the "ENTER" key to save the parameter. Drive will confirm the change "END". Display will return to step 8.	End C6-02
13. Press "ESC" key until back at the initial display.	F 0.00

PART NAME	
YASKAWA J7 TO J1000	
SCALE	WHERE USED
NONE	RETROFIT YASKAWA J7 TO YASKAWA J1000
	
DWG No. J7 to J1000	
M&R PRINTING EQUIPMENT, INC.	SHEET
1 N. 372 Main Street Glen Ellyn, Illinois 60139	1
REV.	Av1

THIS DRAWING AND/OR SPECIFICATION IS THE PROPERTY OF M & R PRINTING EQUIPMENT INC. IT IS ISSUED IN STRICT CONFIDENCE AND SHALL NOT BE REPRODUCED, COPIED OR DISCLOSED TO OTHERS OR USED AS THE BASIS FOR THE MANUFACTURE OR SALE OF APPARATUS WITHOUT THE PERMISSION OF THE OWNER.

OWN BY	DATE
CM	03/10/10
ENG APP.	DATE

This document was created with Win2PDF available at <http://www.win2pdf.com>.  
The unregistered version of Win2PDF is for evaluation or non-commercial use only.  
This page will not be added after purchasing Win2PDF.